



Recreus was founded in June of 2013 by Ignacio García, based in (Alicante) Spain. After two years of R&D into TPE thermoplastic-elastomers, we developed the worlds first trully elastic filament for FDM Printers - FILAFLEX. Our company is fully dedicated to the 3d truly printing world through the development of 3D printing filaments and mechanical design.

Our philosophy is to keep pushing towards the 3rd industrial revolution by developing new filaments, new hot-ends and new extruders. We give back to the 3d printing community by making available all our designs and improvements for free.

We have recently invested in two new production lines with full automation of the industrial process. Our goal is to offer our partners and customers only the highest quality filaments.

Recreus is currently exporting FilaFlex to 63 different countries. Our strategic location in Spain allows us to provide reduced shipping times because we believe that our customers and resellers should not have to wait. Ships in 24h-72hrs to any part of the world.

FilaFlex

WHAT IS FILAFLEX?

FilaFlex is a TPE thermoplastic elastomer with a polyurethane base, it is the most elastic filament available for 3d printers and allows you to print elastic parts with 700% stretching until breaking.

FilaFlex has excellent bonding properties with PLA, ABS, HIPS, NYLON and almost any printing material. This allows for the creation of composite parts that combine both hard and soft materials in one print.

New combinations that provide for a whole new world of possibilities!!



TECHNICAL SPECS.

DIAMETER	2.85 mm / 1.75 mm
TOLERANCE	+/- 0.02mm
PRINTING SPEED	30-90 MM/S
PRINTING TEMPERATURE	215-245 °C
DENSITY	1215 KG/M ³
SHORE HARDENSS (A)	84
TENSILE STRENGHT	39 MPA
STRAIN TO BREAK	700%
TOXICITY	Non-hazardous substance according to the GHS classification
SPOOL GROSS WEIGHT	550 gr. / 300 gr.
	500gr. / 250gr.

The most elastic filament for 3d printers



FEATURES

- ✓ High elasticity - 700% stretching until breaking.
- ✓ Compatible with bowden extruders using the recreus hotend.
- ✓ Dual extrusion revolution, combine FILAFLEX with PLA or ABS and create new hibrid prints with all new capabilities.
- ✓ Solvent, acetone, thinner and fuel resistant.
- ✓ No heated bed, kapton, blue tape or hairspray needed.
- ✓ High speed printing - up to 140 mm/s with the recreus hotend.



TECHNICAL SUPPORT



Recreus offers technical support to solve any occasional issues printing with FilaFlex (elastic Filament) on different printer models.

We have an online chat at www.recreus.com where you can speak directly with us to resolve any doubts and questions or just ask for advice.

We'll be happy to help!

DISTRIBUTORS

All Recreus partners get reseller discounts on ALL our products. As a manufacturer, we offer all our partners full technical assistance, updated improvements and 3D showcasing models in order to drive our partners sales

Resellers have access to the Recreus reseller zone:

- Spool Pictures in high- res.
- All new 3d models with high-res pictures.
- MSDS Medical safety data sheet.
- Slicers software profiles: SLIC3R, CURA, CRAFTWARE, KISSLICER, MAKERWARE
- FAQ
- New improvements.



FAQ

Is my 3d printer FilaFlex friendly?

We have tested FilaFlex on multiple 3D printers: Makerbot Rep 1 & 2, RepRap Prusa i2 - i3, RepRap BCN, Witbox, Sharebot, Ultimaker 1 & 2, PrinterBot, Mendel Max, LeWiHe, Lulzbot. Works on almost all printers using ABS settings:

Temperature: 235C
Speed: 30mm/S
Layer height: 0.2MM
Retraction: 2mm

Recommendations.

We recommend using direct drive extruders. Although we have tested FilaFlex using Bowden extruders and achieving successful prints at very low speeds, Bowden extruders are not highly recommended due to the long distance between the hotend and stepper motor.

When you try FilaFlex for the first time we recommend starting with low speeds (25mm/s) and high temperatures (245°C). As you gain experience you will be able to increase the speed and decrease the temperature in order to achieve high quality prints.



3D PRINTER DEVELOPERS

We offer a totally free service for 3D printer developers. If your company is designing a new 3D printer for the market we'd be glad to help you adapt it to print both elastic and rigid filaments right from day one. Get it ready to print fast and precise using any kind of material.

"It's hard to imagine today that a new 3D printer cannot print using soft or elastic filaments, we offer solutions, let us help!"

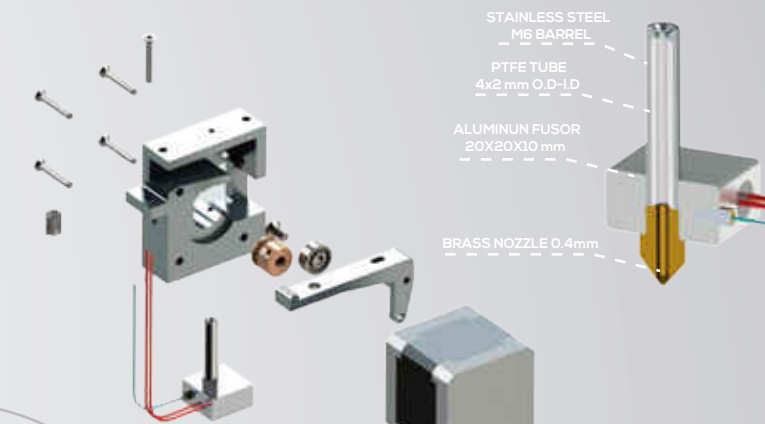

CORRECT EXTRUDER CONFIGURATION

